

Kevytrakenteinen jäänalainen pohja- ankkuroitu Boiju

Koko: Ø 0,9m x korkeus 1,4m

Paino 90 kg

Toiminta-alue: 0-50m

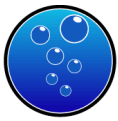

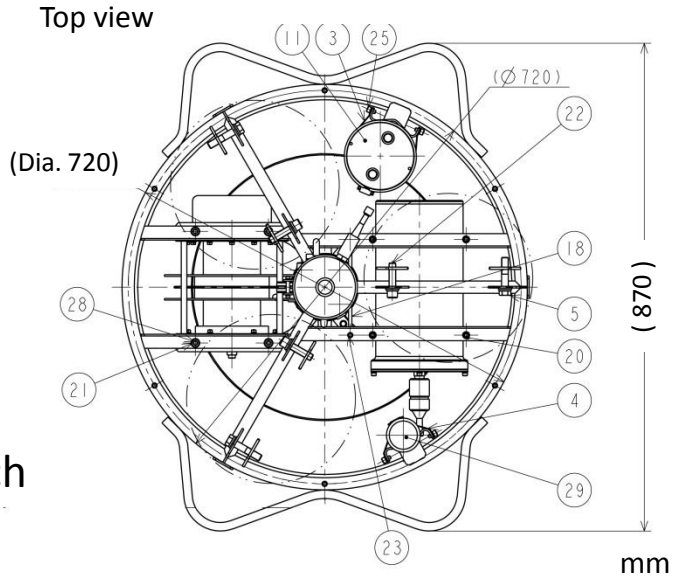

**Sketch: GWM-SEASAW Winch  
(Un-controlled)**

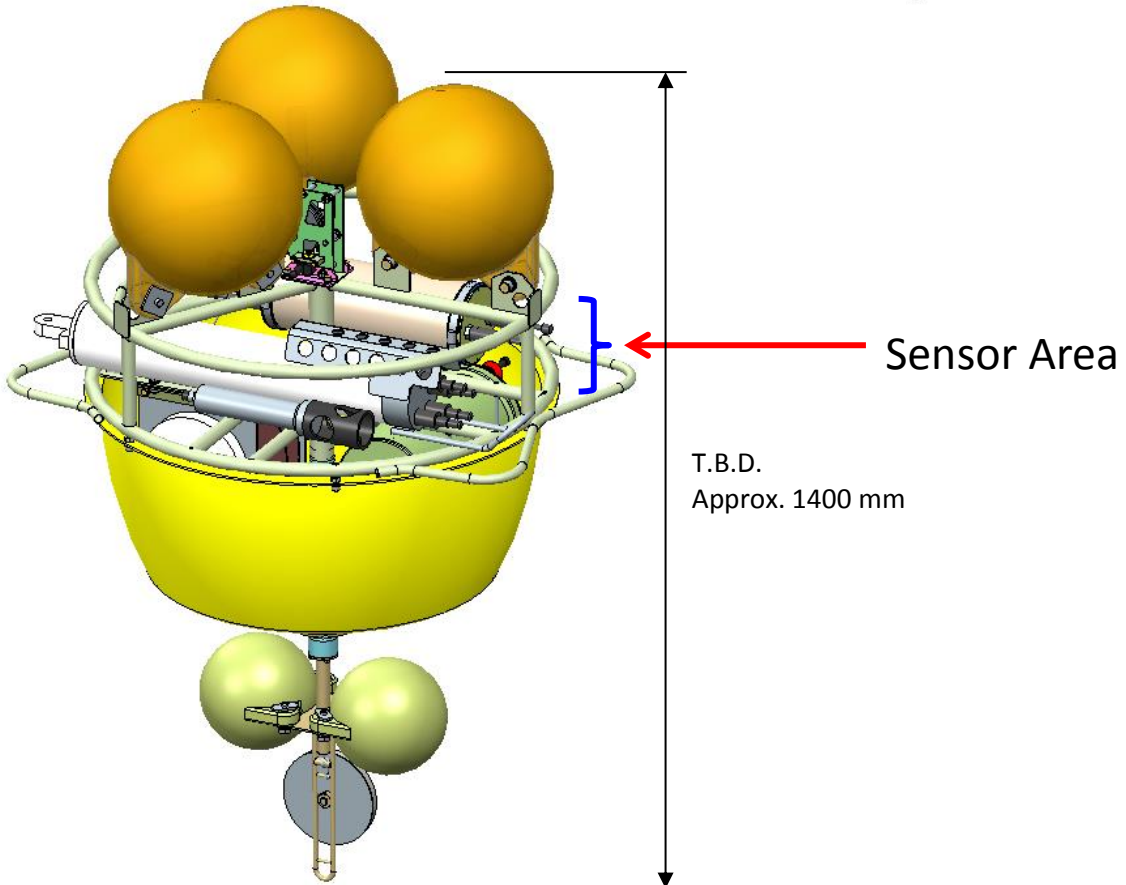

Weight: Approx. 90kg (air) as whole system  
-9kgf(water) as whole system